

REVISION HISTORY		
REV	DATE	ECN
-	04/07/22	22-0323
A	01/18/23	23-0061

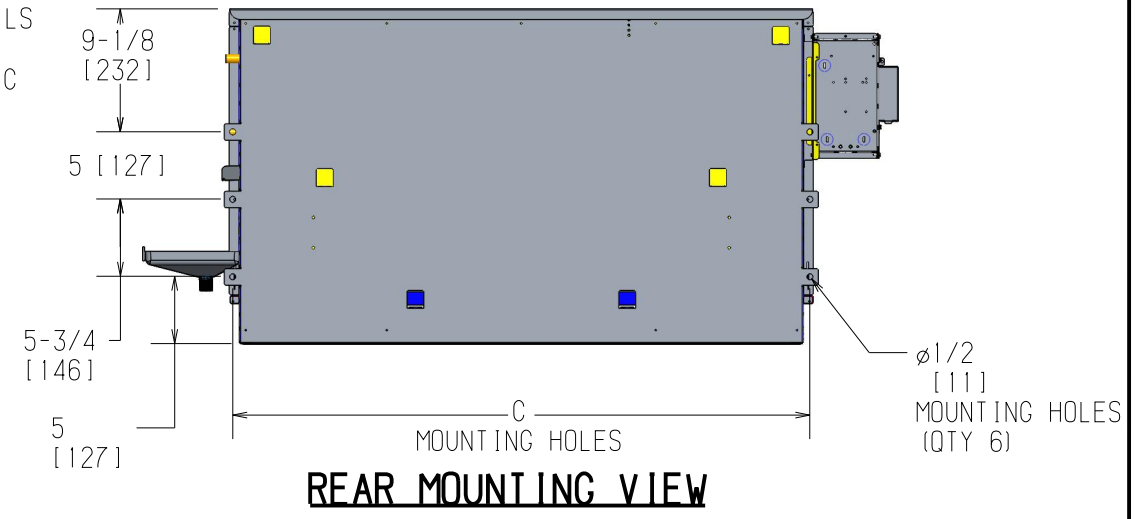
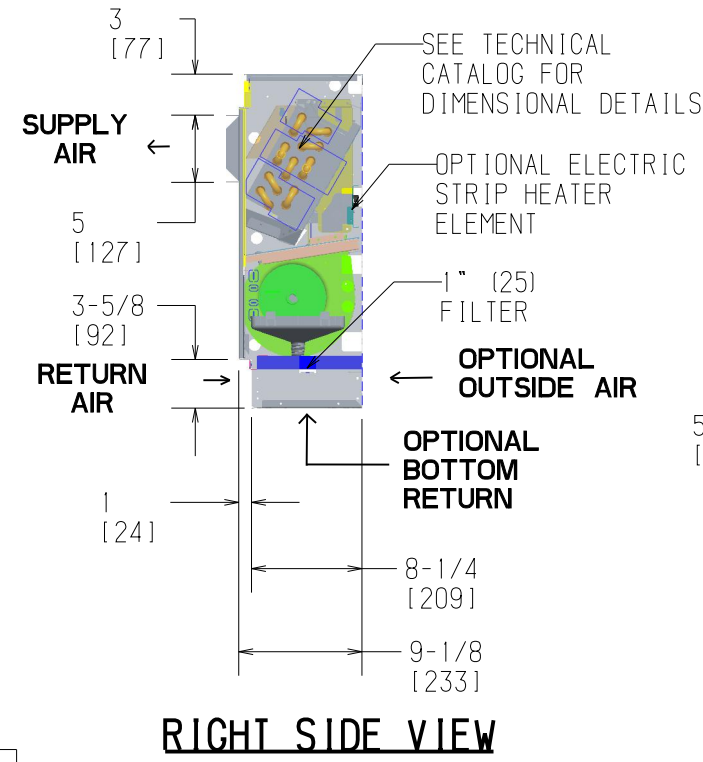
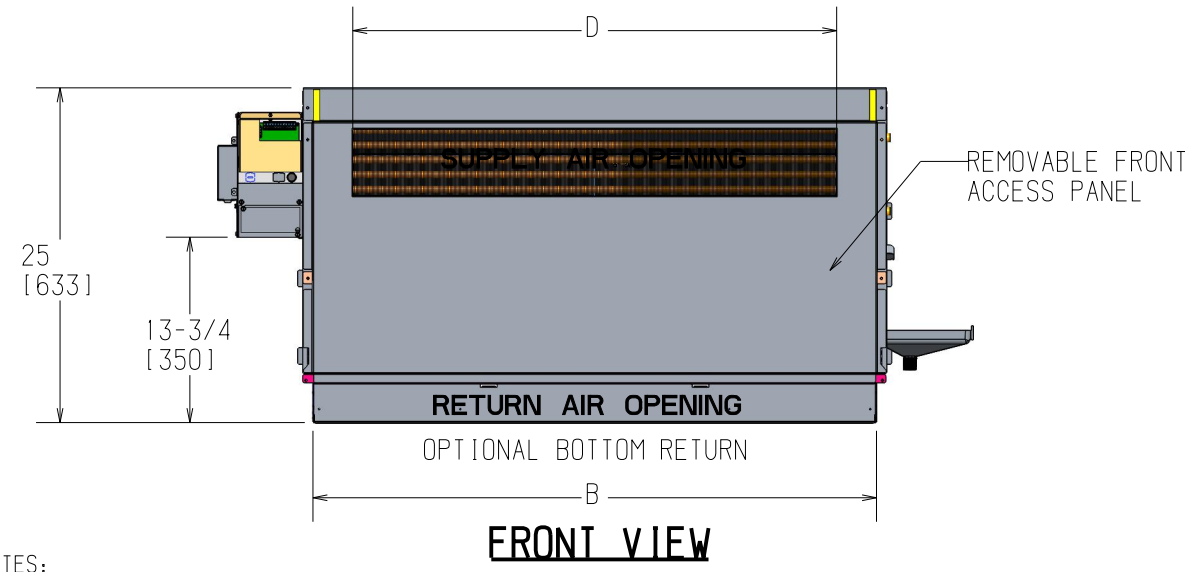
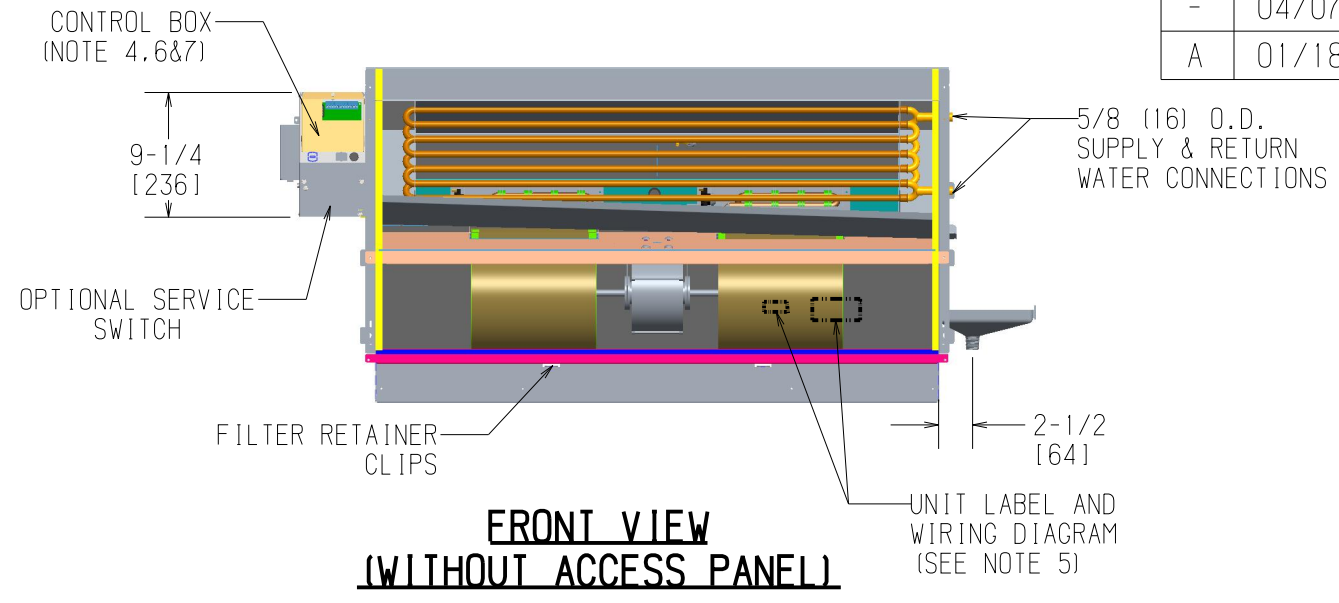
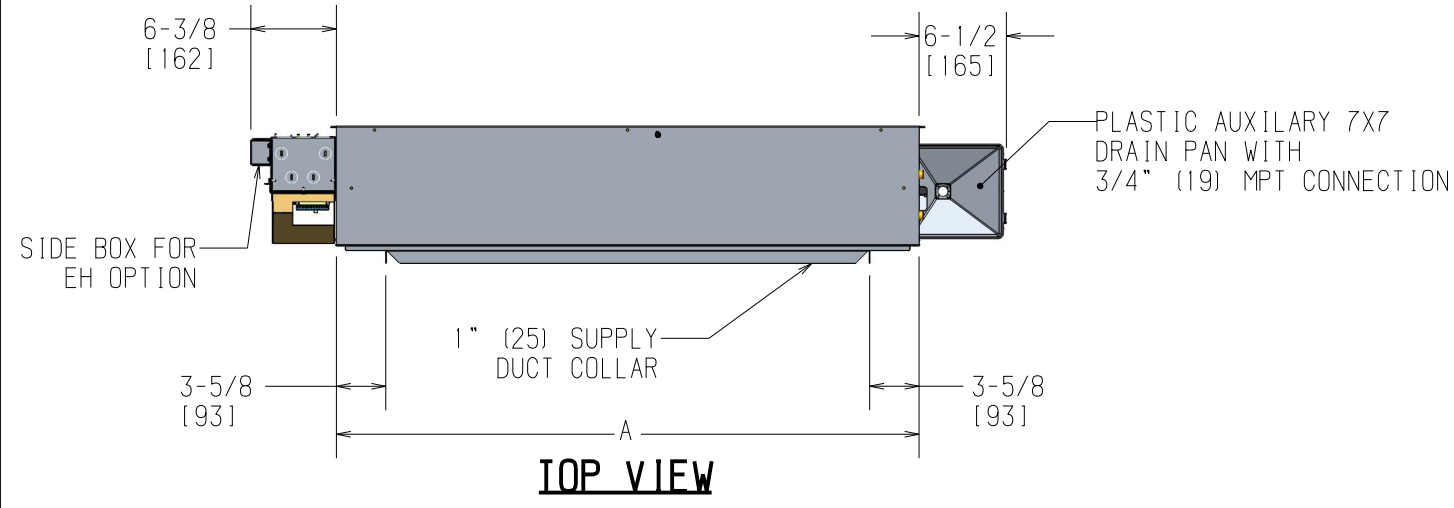

- NOTES:
1. RH COIL SHOWN, LH OPPOSITE.
  2. ALL DIMENSIONS ARE +/- .25 (6). DRAWING NOT TO SCALE.
  3. PRODUCT SPECIFICATIONS ARE SUBJECT TO CHANGE WITHOUT NOTICE.
  4. CONTROL BOX SIZE AND POSITION MAY VARY (CONSULT FACTORY)
  5. POSITION MAY VARY.
  6. SERVICE ACCESS IS LOCATED ON THE FRONT OF THE CONTROL BOX.
  7. KNOCKOUTS ON THE BOTTOM AND SIDE OF THE CONTROL BOX FOR INCOMING POWER CONNECTIONS

Unit Model	Dimensions - Inches (Millimeters)				Quantity/Unit	
	A	B	C	D	Blower	Motor
FHA 02	23-1/2 (597)	22 (559)	23 (584)	16 (406)	1	1
FHA 03	27-1/2 (699)	26 (660)	27 (686)	20 (508)	1	1
FHA 04	33-1/2 (851)	32 (813)	33 (838)	26 (660)	2	1
FHA 06	43-1/2 (1105)	42 (1067)	43 (1092)	36 (914)	2	1
FHA 08	45-1/2 (1156)	44 (1118)	45 (1143)	38 (965)	2	1
FHA 10	59-1/2 (1511)	58 (1473)	59 (1499)	52 (1321)	4	2
FHA 12	67-1/2 (1715)	66 (1676)	67 (1702)	60 (1524)	4	2

**IEC**  
International Environmental

TITLE: VERT HIDEAWAY FRNT SPLY FHA  
OPTIONAL ELECTRIC HEAT SHOWN

DWG NO: **1100-90050667**

REV: **A**

DRAWN: J. BRADFORD	DATE: 06/22/22	APPROVED: J. FUSON	DATE: 06/22/22
--------------------	----------------	--------------------	----------------